



Model No. LCHW20101

Medium security chest



Best Used For:



Fire



Flood

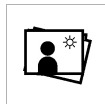

Pictures

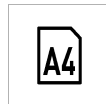

A4 Paper Documents



Small Electronics



Storage Devices, USB Flash Drives

Overview & Features

Product Features

- Fire and water resistant construction
- UL/ETL verified 30 minutes fire protection for documents, official papers, as well as digital items (CD, USB sticks) up to 843°C
- ETL verified for water submersion to protect documents and other valuable items from flood damage
- Key lock – includes 2 keys
- Privacy key lock keeps documents and valuables away from prying eyes and prevents the lid from opening in the event of a fire
- Fits A4 documents

Certifications



Product Details

The Master Lock No. LCHW20101 Medium Security Chest protects your family's most important paper documents (fits A4 paper size), media, and valuables from fire and flood damage. The integrated handle make the chest easy to carry.

Product Specifications

Product Number	LCHW20101
Description	Retail Boxed Packaging
Master Carton Qty	1
Exterior dimensions (H x W x D)	16,8cm x 39,1cm x 36,3cm
Interior dimensions (H x W x D)	11,2cm x 32,5cm x 21,6cm
Interior Volume	7,8L
Weight W/o Packaging	9,3kg
Colour	Charcoal Grey

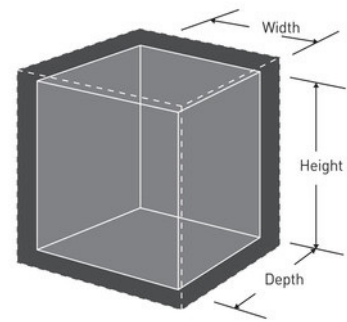

Master Lock Europe S.A.S.

131, avenue Charles de Gaulle - 92200 Neuilly sur Seine - France
O:+33-1-41437200 | F:+33-1-41437204
www.masterlock.eu